

UNDELIVERED 2006

Variable dimensions

A - PROPOSAL

The briefcase can either be exhibited or not.
The briefcase can either be exhibited opened or closed
The briefcase can either be exhibited with or without its components.
The briefcase can either be exhibited next to another piece or isolated.
The briefcase can either be exhibited on the floor or on a table

The contents of the briefcase can be exhibited separately according to the attached instructions.

The title cards can either be used or not.

The description written on the provided title cards has to be displayed accordingly to the gallery's own communication scheme

B - INSTRUCTIONS

1.1- Place the briefcase in the exhibition space
Place a title card next to the intervention

2.1- Drill a hole in a wall
Unplug the drill
Leave the drill in the wall
Place a title card next to the intervention

2.2- Drill a hole 10 mm wide and 4 inches deep in the floor
Gently remove the drill
Leave the dust mound as it is for the duration of the exhibition
Place a title card next to the intervention

2.3- Drill a hole (choose its thickness) over a door, near a skirting board, under a window
Place a title card next to the intervention

3.1- Place the spirit level on an artwork or an architectural element
Leave it for the duration of the exhibition
Place a title card next to the intervention

4.1- With the chalk, draw extending lines of the upper or lower border of artworks hung on a wall
Leave the lines visible all along the wall for the duration of the exhibition
Place a title card next to the intervention

5.1- Tight a plumbline down to the floor next to an artwork or an architectural element
Fix the plumbline to the ceiling and keep it still for the duration of the exhibition
Place a title card next to the intervention

6.1- Draw a point on a partition or a door opposite to a chosen target in the exhibition
Drill a 3 millimetres hole
Position the rangefinder behind the drilled surface its ray coming out of the hole
Keep the rangefinder switched on for the duration of the exhibition
Place a title card next to the intervention

8.1- Display the pair of white gloves in a chosen position
Place a title card next to the intervention

C - LOAN FORM

9.1- The envelop contains an information form to be filled up by the institution responsible of the exhibition







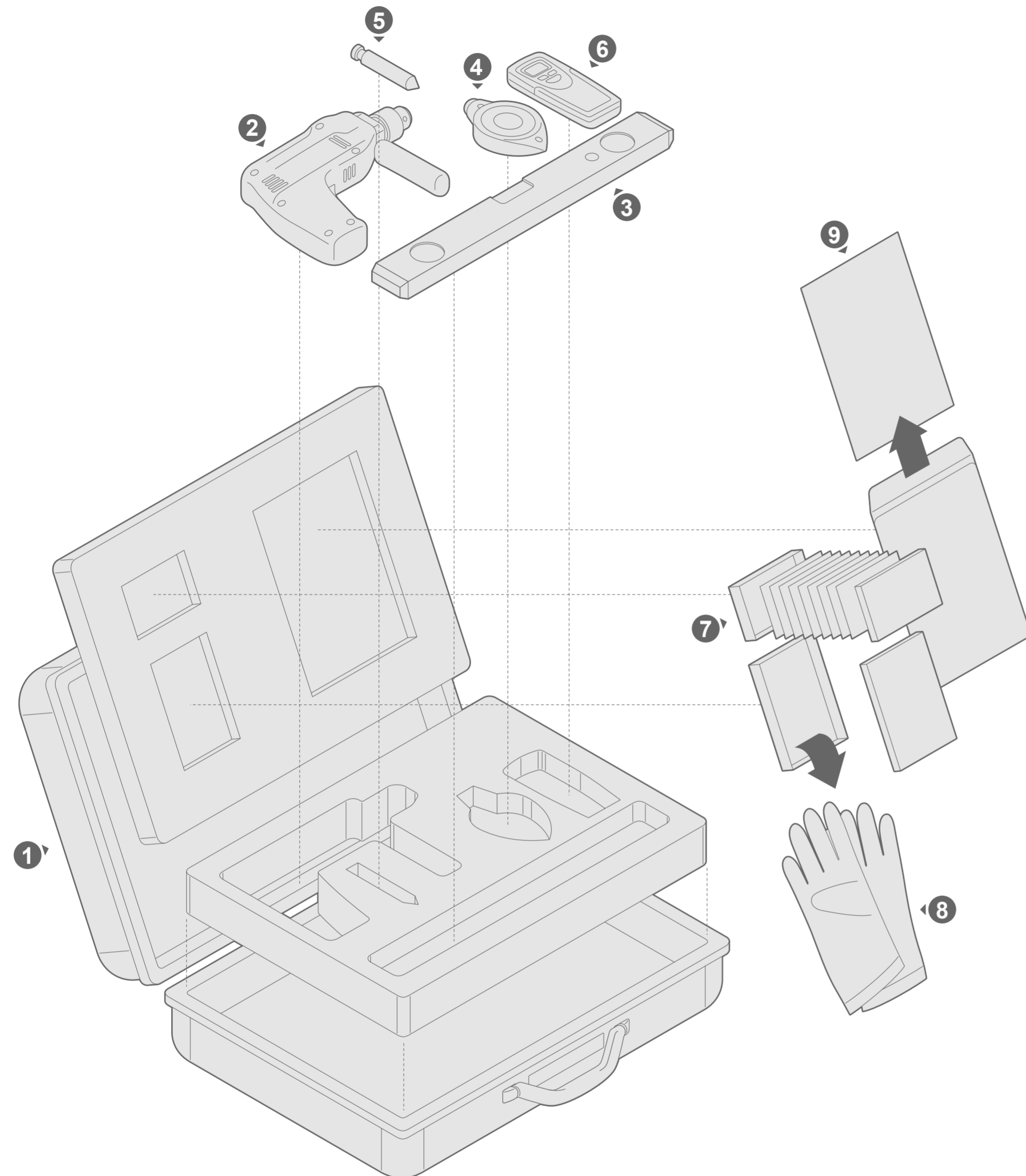

Mention the location, the date and the title of the exhibition
Mention the institution's / the person in charge's details
Mention the name of the curator of the exhibition
Mention the name of the technician in charge of the display of the intervention(s)
Mention the title of the artwork(s) shown in the same room
Draw a map of the exhibition's installation
Take a picture of the piece in its situation
Take a picture of each intervention in the exhibition

Date and sign

Put the documents in the envelope provided which must stay in the briefcase

9.2- This instructions form can be considered as part of the work, as much as the briefcase itself and its content
This instructions form can either be exhibited or not



| | | | | | | | | |
|---|---|---------------------|---|---|-------------|---|---|---------------------|
| 1 |  | Aluminium briefcase | 4 |  | Chalk line | 7 |  | Exhibition captions |
| 2 |  | Electric drill | 5 |  | Plumb line | 8 |  | White gloves |
| 3 |  | Spirit level | 6 |  | Rangefinder | 9 |  | Notice |